

Chapter 3

Boolean Algebra and Digital Logic

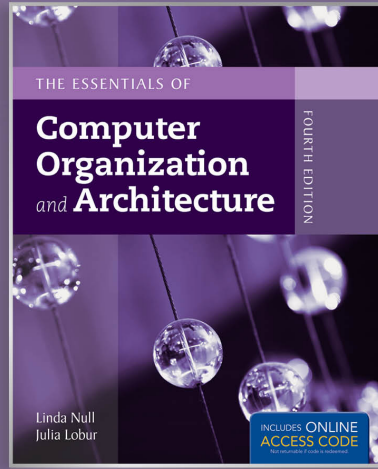

© Odua Images/Shutterstock, Inc. Copyright © 2014 by Jones & Bartlett Learning, LLC an Ascend Learning Company
www.jblearning.com

Chapter 3 Objectives

- Understand the relationship between Boolean logic and digital computer circuits.
- Learn how to design simple logic circuits.
- Understand how digital circuits work together to form complex computer systems.

2

3.1 Introduction

- In the latter part of the nineteenth century, George Boole incensed philosophers and mathematicians alike when he suggested that logical thought could be represented through mathematical equations.
 - *How dare anyone suggest that human thought could be encapsulated and manipulated like an algebraic formula?*
- Computers, as we know them today, are implementations of Boole's *Laws of Thought*.
 - John Atanasoff and Claude Shannon were among the first to see this connection.

G. Boole: “*An Investigation of the Laws of Thought*” (1854)

3

3.1 Introduction

- In the middle of the twentieth century, computers were commonly known as “thinking machines” and “electronic brains.”
 - Many people were fearful of them.
- Nowadays, we rarely ponder the relationship between electronic digital computers and human logic. Computers are accepted as part of our lives.
 - Many people, however, are still fearful of them.
- In this chapter, you will learn the simplicity that constitutes the essence of the machine.

John von Neumann: “*Theory of Self-Reproducing Automata*” (1966)

4

3.2 Boolean Algebra

- Boolean algebra is a mathematical system for the manipulation of variables that can have one of two values.
 - In formal logic, these values are “true” and “false.”
 - In digital systems, these values are “on” and “off,” 1 and 0, or “high” and “low”.
- Boolean expressions are created by performing operations on Boolean variables.
 - Common Boolean operators include AND, OR, and NOT.

5

3.2 Boolean Algebra

- A Boolean operator can be completely described using a **truth table**.
- The truth table for the Boolean operators AND and OR are shown at the right
- The AND operator is also known as a *Boolean product*. The OR operator is the *Boolean sum*.

X AND Y

X	Y	XY
0	0	0
0	1	0
1	0	0
1	1	1

X OR Y

X	Y	X+Y
0	0	0
0	1	1
1	0	1
1	1	1

6

3.2 Boolean Algebra

- The truth table for the Boolean NOT operator is shown at the right.
- The NOT operation is most often designated by a prime mark (X'). It is sometimes indicated by an overbar (\overline{X}) or an “elbow” ($\neg X$).

NOT X

X	X'
0	1
1	0

7

3.2 Boolean Algebra

- A **Boolean function** has:
 - At least one Boolean variable,
 - At least one Boolean operator, and
 - At least one input from the set $\{0,1\}$.
- It produces an output that is also a member of the set $\{0,1\}$.

8

3.2 Boolean Algebra

- The truth table for the Boolean function:
 $F(x, y, z) = xz' + y$ is shown at the right.
- To make evaluation of the Boolean function easier, the truth table contains extra (shaded) columns to hold evaluations of subparts of the function.

$$F(x, y, z) = xz' + y$$

x	y	z	z'	xz'	xz' + y
0	0	0	1	0	0
0	0	1	0	0	0
0	1	0	1	0	1
0	1	1	0	0	1
1	0	0	1	1	1
1	0	1	0	0	0
1	1	0	1	1	1
1	1	1	0	0	1

9

3.2 Boolean Algebra

- As with common arithmetic, Boolean operations have rules of precedence.
- The NOT operator has highest priority, followed by AND and then OR.
- This is how we chose the (shaded) function subparts in our table.

$$F(x, y, z) = xz' + y$$

x	y	z	z'	xz'	xz' + y
0	0	0	1	0	0
0	0	1	0	0	0
0	1	0	1	0	1
0	1	1	0	0	1
1	0	0	1	1	1
1	0	1	0	0	0
1	1	0	1	1	1
1	1	1	0	0	1

10

3.2 Boolean Algebra

- Digital computers contain circuits that implement Boolean functions.
- The simpler that we can make a Boolean function, the smaller the circuit that will result.
 - Simpler circuits are cheaper to build, consume less power, and run faster than complex circuits.
- With this in mind, we always want to reduce our Boolean functions to their simplest form.
- There are a number of Boolean identities that help us to do this.

11

3.2 Boolean Algebra

- Most Boolean identities have an AND (product) form as well as an OR (sum) form. We give our identities using both forms. Our first group is rather intuitive:

Identity Name	AND Form	OR Form
Identity Law	$1x = x$	$0 + x = x$
Null Law	$0x = 0$	$1 + x = 1$
Idempotent Law	$xx = x$	$x + x = x$
Inverse Law	$xx' = 0$	$x + x' = 1$

Idempotent: can be applied multiple times without changing the result

12

3.2 Boolean Algebra

- Our second group of Boolean identities should be familiar to you from your study of algebra:

Identity Name	AND Form	OR Form
Commutative Law	$xy = yx$	$x+y = y+x$
Associative Law	$(xy)z = x(yz)$	$(x+y)+z = x+(y+z)$
Distributive Law	$x+yz = (x+y)(x+z)$	$x(y+z) = xy+xz$

Commutative: the order can be changed without changing the result

13

3.2 Boolean Algebra

- Our last group of Boolean identities are perhaps the most useful.
- If you have studied set theory or formal logic, these laws are also familiar to you.

Identity Name	AND Form	OR Form
Absorption Law	$x(x+y) = x$	$x + xy = x$
DeMorgan's Law	$(xy)' = x' + y'$	$(x+y)' = x'y'$
Double Complement Law	$(x)'' = x$	

14

3.2 Boolean Algebra

- We can use Boolean identities to simplify:

$$F(x, y, z) = xy + x'z + yz$$

$$\begin{aligned}
 F(x, y, z) &= xy + x'z + yz && \\
 &= xy + x'z + yz(1) && \text{(Identity)} \\
 &= xy + x'z + yz(x + x') && \text{(Inverse)} \\
 &= xy + x'z + (yz)x + (yz)x' && \text{(Distributive)} \\
 &= xy + x'z + x(yz) + x'(zy) && \text{(Commutative)} \\
 &= xy + x'z + (xy)z + (x'z)y && \text{(Associative twice)} \\
 &= xy + (xy)z + x'z + (x'z)y && \text{(Commutative)} \\
 &= xy(1 + z) + x'z(1 + y) && \text{(Distributive)} \\
 &= xy(1) + x'z(1) && \text{(Null)} \\
 &= xy + x'z && \text{(Identity)}
 \end{aligned}$$

15

3.2 Boolean Algebra

- Sometimes it is more economical to build a circuit using the complement of a function (and complementing its result) than it is to implement the function directly.
- DeMorgan's law provides an easy way of finding the complement of a Boolean function.
- Recall DeMorgan's law states:

$$(xy)' = x' + y' \quad \text{and} \quad (x + y)' = x'y'$$

3.2 Boolean Algebra

- DeMorgan's law can be extended to any number of variables.
- Replace each variable by its complement and change all ANDs to ORs and all ORs to ANDs.
- Thus, we find that the complement of:

$$F(x, y, z) = (xy) + (x'y) + (xz')$$

is:

$$\begin{aligned} F'(x, y, z) &= ((xy) + (x'y) + (xz'))' \\ &= (xy)' (x'y)' (xz')' \\ &= (x' + y') (x + y') (x' + z) \end{aligned}$$

17

3.2 Boolean Algebra

- Through our exercises in simplifying Boolean expressions, we see that there are numerous ways of stating the same Boolean expression.
 - These “synonymous” forms are *logically equivalent*.
 - Logically equivalent expressions have identical truth tables.
- In order to eliminate as much confusion as possible, designers express Boolean functions in *standardized* (or *canonical*) form.

18

3.2 Boolean Algebra

- There are two canonical forms for Boolean expressions: sum-of-products and product-of-sums.
 - Recall the Boolean product is the AND operation and the Boolean sum is the OR operation.
- In the **sum-of-products** form, ANDed variables are ORed together.
 - For example: $F(x, y, z) = xy + xz + yz$
- In the **product-of-sums** form, ORed variables are ANDed together.
 - For example: $F(x, y, z) = (x+y)(x+z)(y+z)$

19

3.2 Boolean Algebra

- It is easy to convert a function to sum-of-products form using its truth table.
- We are interested in the values of the variables that make the function true (=1).
- Using the truth table, we list the values of the variables that result in a true function value.
- Each group of variables is then ORed together.

$$F(x, y, z) = xz' + y$$

x	y	z	xz' + y
0	0	0	0
0	0	1	0
0	1	0	1
0	1	1	1
1	0	0	1
1	0	1	0
1	1	0	1
1	1	1	1

20

3.2 Boolean Algebra

- The sum-of-products form for our function is:

$$F(x, y, z) = (x'yz') + (x'yz) + (xy'z') + (xyz')$$

We note that this function is not in simplest terms. Our aim is only to rewrite our function in canonical sum-of-products form.

$$F(x, y, z) = xz' + y$$

x	y	z	$xz' + y$
0	0	0	0
0	0	1	0
0	1	0	1
0	1	1	1
1	0	0	1
1	0	1	0
1	1	0	1
1	1	1	1

21

3.3 Logic Gates

- We have looked at Boolean functions in abstract terms.
- In this section, we see that Boolean functions are implemented in digital computer circuits called **gates**.
- A gate is an electronic device that produces a result based on two or more input values.
 - In reality, gates consist of one to six transistors, but digital designers think of them as a single unit. The basic physical component of a computer is the transistor; the basic logic component is the gate.
 - Integrated circuits contain collections of gates suited to a particular purpose.

22

3.3 Logic Gates

- The three simplest gates are the AND, OR, and NOT gates.

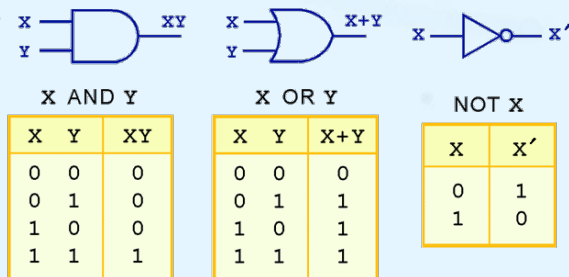

- They correspond directly to their respective Boolean operations, as you can see by their truth tables.

23

3.3 Logic Gates

- Another very useful gate is the exclusive OR (XOR) gate.
- The output of the XOR operation is true only when the values of the inputs differ.

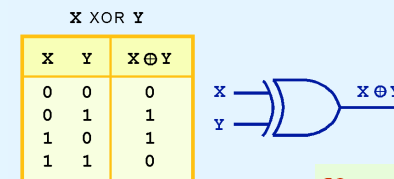

Note the special symbol \oplus for the XOR operation.

24

3.3 Logic Gates

- NAND and NOR are two very important gates. Their symbols and truth tables are shown at the right.

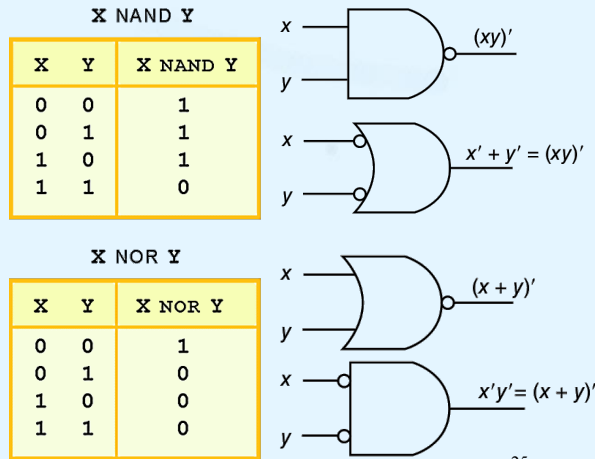

25

3.3 Logic Gates

- NAND and NOR are known as *universal gates* because any Boolean function can be constructed using only NAND or only NOR gates.
- They are inexpensive to manufacture.

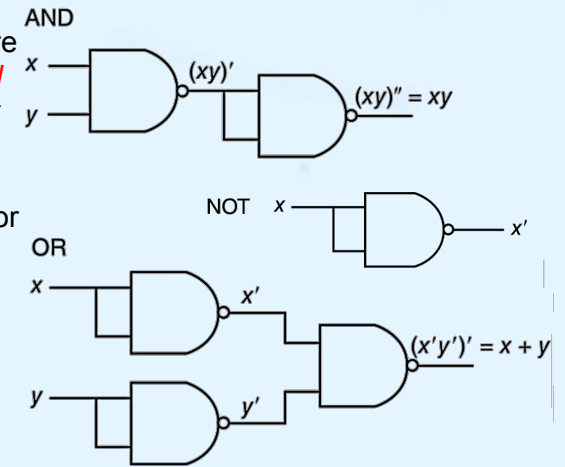

26

3.3 Logic Gates

- Gates can have multiple inputs and more than one output.
 - A second output can be provided for the complement of the operation.
 - We'll see more of this later.

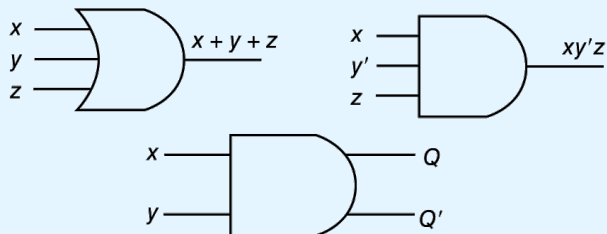

27

3.4 Digital Components

- Typically, gates are not sold individually; they are sold in units called *integrated circuits*.
- Simple SSI integrated circuit with 4 NAND gates

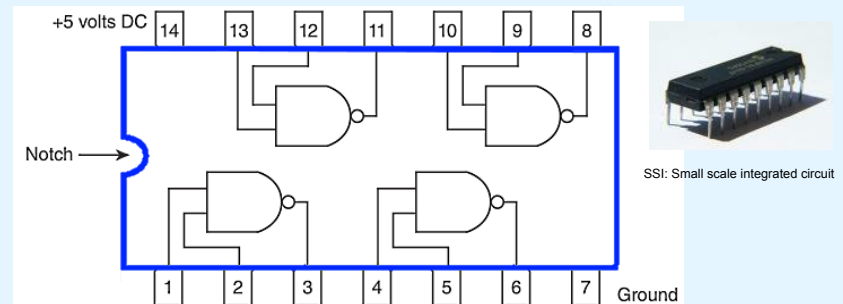

28

3.4 Digital Components

- The Boolean circuit:

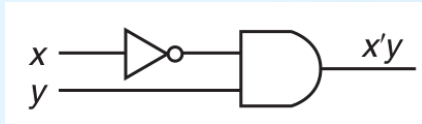

- Can be rendered using only NAND gates as:

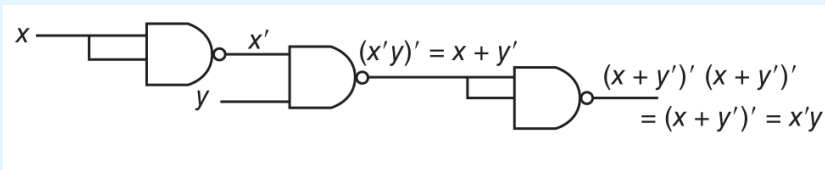

29

3.4 Digital Components

- So we can wire the pre-packaged circuit to implement our function:

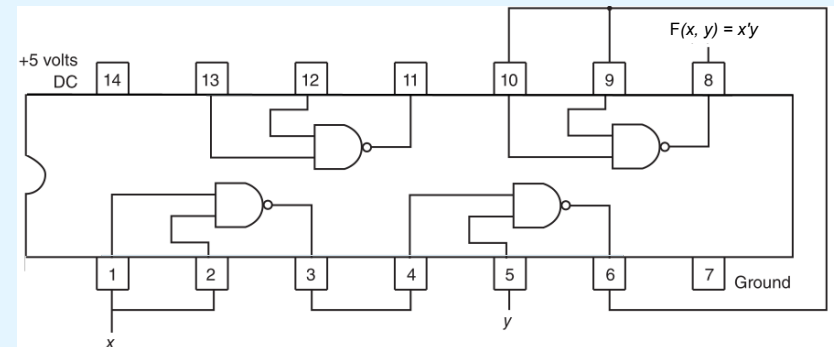
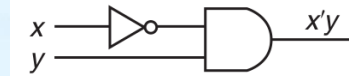

3.4 Digital Components

- The main thing to remember is that combinations of gates implement Boolean functions.
- The circuit below implements the Boolean function: $F(x, y, z) = x + y'z$

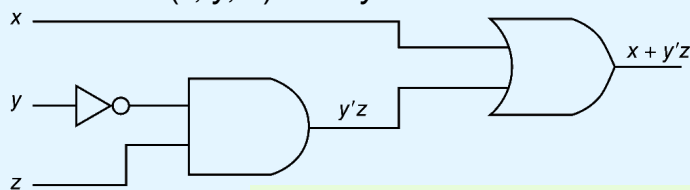

We simplify our Boolean expressions so that we can create simpler circuits.

31

3.5 Combinational Circuits

- We have designed a circuit that implements the Boolean function: $F(x, y, z) = x + y'z$
- This circuit is an example of a **combinational logic** circuit. The output is a strict *combination* of the current inputs.
- Combinational logic circuits produce a specified output (almost) at the instant when input values are applied.
 - In a later section, we will explore circuits where this is not the case.

32

3.5 Combinational Circuits

- Combinational logic circuits give us many useful devices.
- One of the simplest is the *half adder*, which finds the sum of two bits.
- We can gain some insight into the construction of a half adder by looking at its truth table, shown at the right.

Inputs		Outputs	
X	Y	Sum	Carry
0	0	0	0
0	1	1	0
1	0	1	0
1	1	0	1

33

3.5 Combinational Circuits

- As we see, the sum can be found using the XOR operation and the carry using the AND operation.

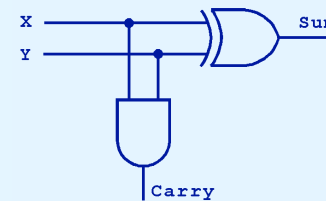

Inputs		Outputs	
X	Y	Sum	Carry
0	0	0	0
0	1	1	0
1	0	1	0
1	1	0	1

34

3.5 Combinational Circuits

- We can change our half adder into a *full-adder* by including gates for processing the carry bit.
- The truth table for a full-adder is shown at the right.

Inputs			Outputs	
X	Y	Carry In	Sum	Carry Out
0	0	0	0	0
0	0	1	1	0
0	1	0	1	0
0	1	1	0	1
1	0	0	1	0
1	0	1	0	1
1	1	0	0	1
1	1	1	1	1

35

3.5 Combinational Circuits

- How can we change the half adder shown below to make it a full-adder?

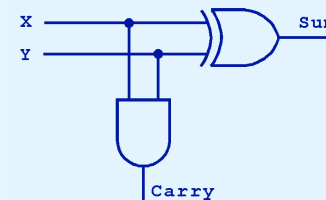

Inputs			Outputs	
X	Y	Carry In	Sum	Carry Out
0	0	0	0	0
0	0	1	1	0
0	1	0	1	0
0	1	1	0	1
1	0	0	1	0
1	0	1	0	1
1	1	0	0	1
1	1	1	1	1

36

3.5 Combinational Circuits

- Here is our completed full-adder (composed of two half-adders and an OR gate).

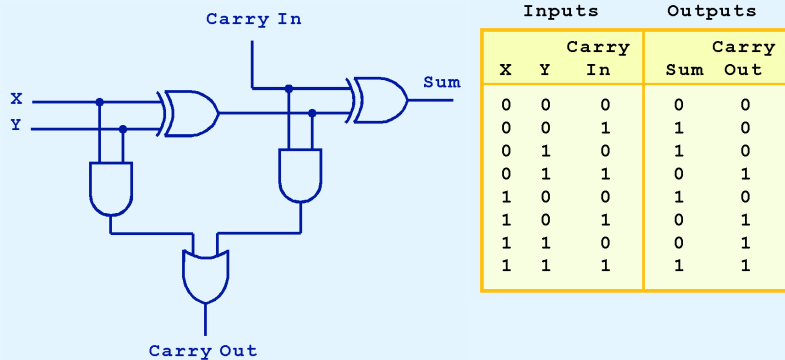

37

3.5 Combinational Circuits

- Just as we combined half adders to make a full adder, full adders can be connected in series.
- The carry bit “ripples” from one adder to the next; hence, this configuration is called a *ripple-carry adder*.

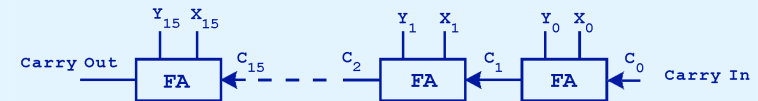

Today's systems employ more efficient adders.

38

3.5 Combinational Circuits

- Decoders** are another important type of combinational circuit.
- Among other things, they are useful in selecting a memory location according to a binary value placed on the address lines of a memory bus.
- Address decoders with n inputs can select any of 2^n locations.

This is a block diagram for a decoder.



39

3.5 Combinational Circuits

- This is what a 2-to-4 decoder looks like on the inside.

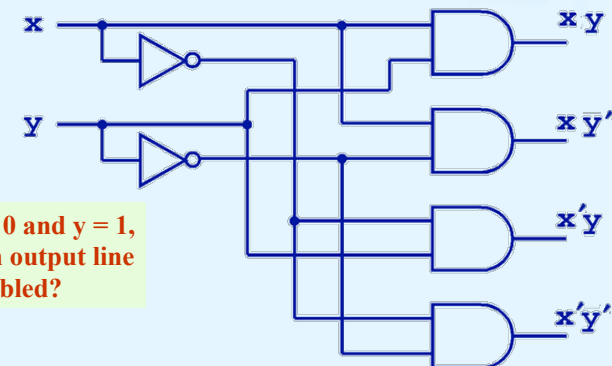

If $x = 0$ and $y = 1$, which output line is enabled?

40

3.5 Combinational Circuits

- A **multiplexer** selects a single output from several inputs.
- The particular input chosen for output is determined by the value of the multiplexer's control lines.
- To be able to select among n inputs, $\log_2 n$ control lines are needed.

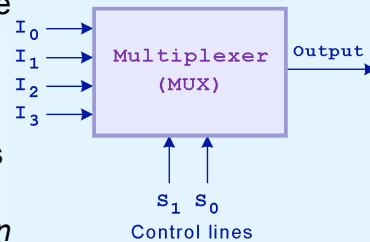

This is a block diagram for a multiplexer.

3.5 Combinational Circuits

- This is what a 4-to-1 multiplexer looks like on the inside.

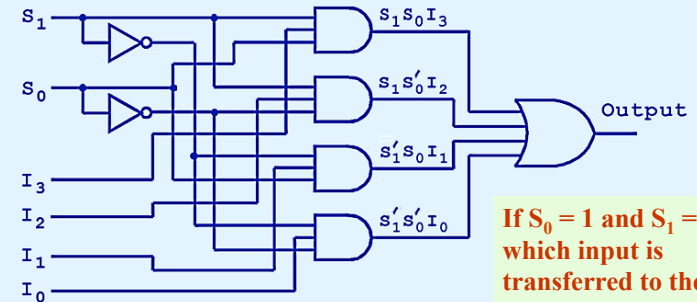

If $S_0 = 1$ and $S_1 = 0$, which input is transferred to the output?

3.5 Combinational Circuits

- This **shifter** moves the bits of a nibble one position to the left or right.

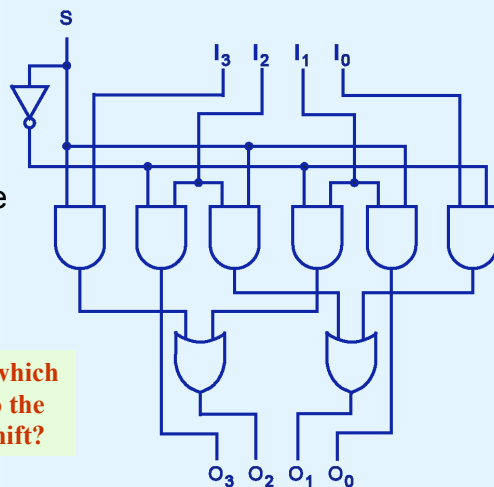

If $S = 0$, in which direction do the input bits shift?

3.5 Combinational Circuits

- A simple 2-bit ALU.

- 00: $A + B$
- 01: NOT A
- 10: $A \text{ OR } B$
- 11: $A \text{ AND } B$

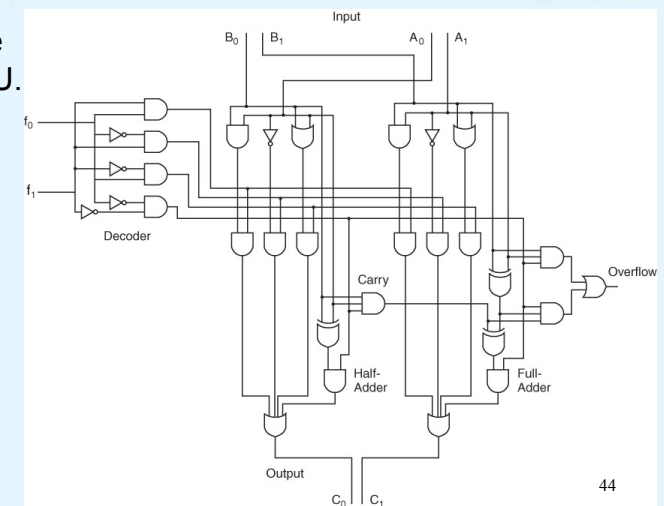

3.6 Sequential Circuits

- Combinational logic circuits are perfect for situations when we require the immediate application of a Boolean function to a set of inputs.
- There are other times, however, when we need a circuit to change its value with consideration to its current state as well as its inputs.
 - These circuits have to “remember” their current state.
- **Sequential logic circuits** provide this functionality for us. Some outputs may depend on past inputs (the *sequence* of inputs over time).

45

3.6 Sequential Circuits

- As the name implies, sequential logic circuits require a means by which events can be sequenced.
- State changes are controlled by clocks.
 - A “clock” is a special circuit that sends electrical pulses through a circuit.
- Clocks produce electrical waveforms such as the one shown below.

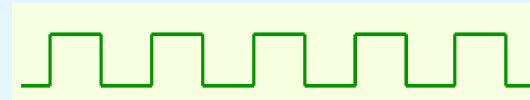

46

3.6 Sequential Circuits

- State changes occur in sequential circuits only when the clock ticks.
- Circuits can change state on the rising edge, falling edge, or when the clock pulse reaches its highest or lowest voltage.

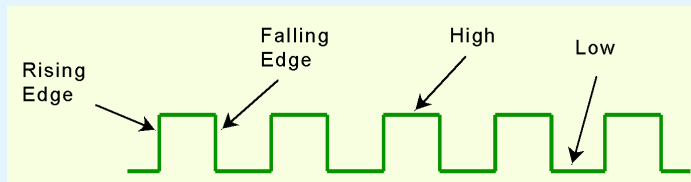

47

3.6 Sequential Circuits

- Circuits that change state on the rising edge, or falling edge of the clock pulse are called **edge-triggered**.
- **Level-triggered circuits** change state when the clock voltage reaches its highest or lowest level.

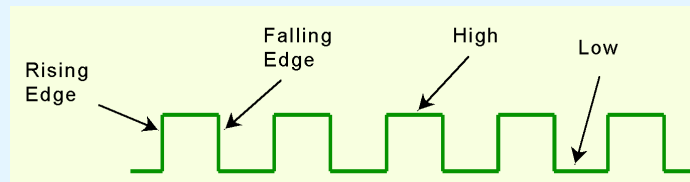

Most sequential circuits are edge-triggered.

48

3.6 Sequential Circuits

- To retain their state values, sequential circuits rely on **feedback**.
- Feedback in digital circuits occurs when an output is looped back to the input.
- A simple example of this concept is shown below.
 - If Q is 0 it will always be 0, if it is 1, it will always be 1. Why?

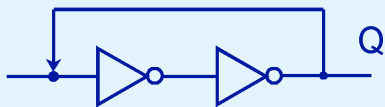

3.6 Sequential Circuits

- You can see how feedback works by examining the most basic sequential logic components, the **SR flip-flop**.
 - The “SR” stands for set/reset.
- The internals of an SR flip-flop (using 2 NOR gates) are shown below, along with its block diagram.

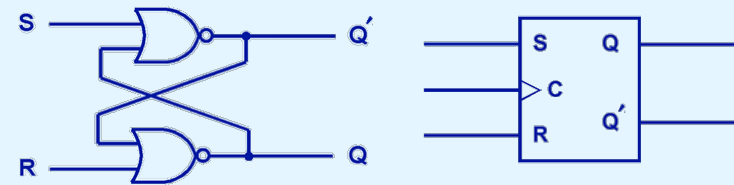

3.6 Sequential Circuits

- The behavior of an SR flip-flop is described by a characteristic table.
- $Q(t)$ means the value of the output at time t . $Q(t+1)$ is the value of Q after the next clock pulse.

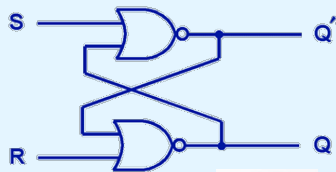

S	R	$Q(t+1)$
0	0	$Q(t)$ (no change)
0	1	0 (reset to 0)
1	0	1 (set to 1)
1	1	undefined

X NOR Y		
X	Y	X NOR Y
0	0	1
0	1	0
1	0	0
1	1	0

3.6 Sequential Circuits

- The SR flip-flop actually has three inputs: S, R, and its current output, Q .
- Thus, we can construct a truth table for this circuit, as shown at the right.
- Notice the two undefined values. When both S and R are 1, the SR flip-flop is unstable.

Present State			Next State
S	R	$Q(t)$	$Q(t+1)$
0	0	0	0
0	0	1	1
0	1	0	0
0	1	1	0
1	0	0	1
1	0	1	1
1	1	0	undefined
1	1	1	undefined

3.6 Sequential Circuits

- If we can be sure that the inputs to an SR flip-flop will never both be 1, we will never have an unstable circuit. This may not always be the case.
- The SR flip-flop can be modified to provide a stable state when both inputs are 1.

- This modified flip-flop is called a **JK flip-flop**, shown at the right.
 - The “JK” is possibly in honor of Jack Kilby (inventor of the integrated circuit, 1958).

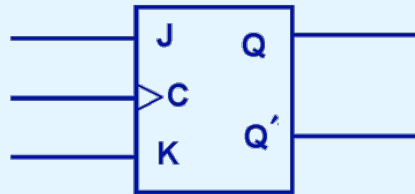

3.6 Sequential Circuits

- At the right, we see how an SR flip-flop can be modified to create a JK flip-flop.
- The characteristic table indicates that the flip-flop is stable for all inputs.

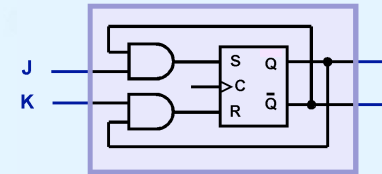

J	K	Q (t+1)
0	0	Q (t) (no change)
0	1	0 (reset to 0)
1	0	1 (set to 1)
1	1	Q (t)

3.6 Sequential Circuits

- Another modification of the SR flip-flop is the **D flip-flop**, shown below with its characteristic table.
- You will notice that the output of the flip-flop remains the same during subsequent clock pulses. The output changes only when the value of D changes.

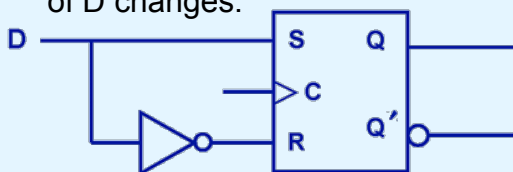

D	Q (t+1)
0	0
1	1

3.6 Sequential Circuits

- The D flip-flop is the fundamental circuit of computer memory.
 - D flip-flops are usually illustrated using the block diagram shown below.
- The characteristic table for the D flip-flop is shown at the right.

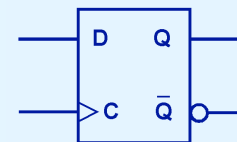

D	Q (t+1)
0	0
1	1

3.6 Sequential Circuits

- The behavior of sequential circuits can be expressed using characteristic tables or **finite state machines** (FSMs).
 - FSMs consist of a set of nodes that hold the states of the machine and a set of arcs that connect the states.
- Moore** and **Mealy** machines are two types of FSMs that are equivalent.
 - They differ only in how they express the outputs of the machine.
- Moore machines place outputs on each node, while Mealy machines present their outputs on the transitions.

57

3.6 Sequential Circuits

- The behavior of a JK flip-flop is depicted below by a Moore machine (left) and a Mealy machine (right).

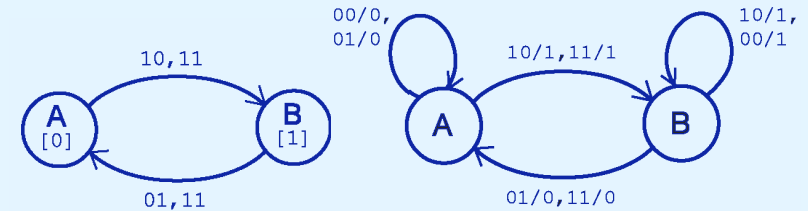

58

3.6 Sequential Circuits

- Although the behavior of Moore and Mealy machines is identical, their implementations differ.

This is our Moore machine.

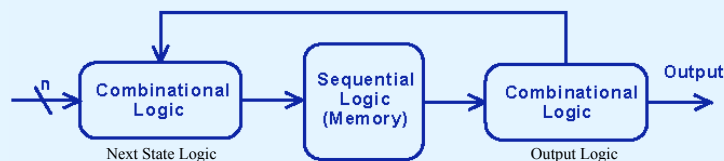
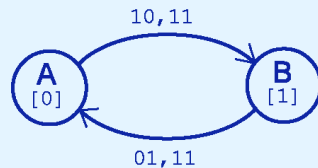

Output depends only on the current state.

59

3.6 Sequential Circuits

This is our Mealy machine.

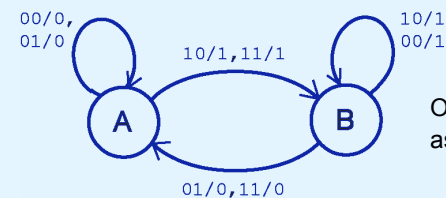
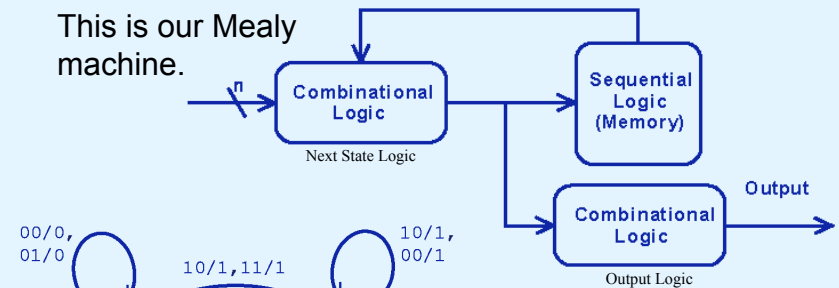

Output depends on the current state as well as the current input.

60

3.6 Sequential Circuits

- It is difficult to express the complexities of actual implementations using only Moore and Mealy machines.
 - For one thing, they do not address the intricacies of timing very well.
 - Secondly, it is often the case that an interaction of numerous signals is required to advance a machine from one state to the next.
- For these reasons, Christopher Clare invented the **algorithmic state machine** (ASM).

The next slide illustrates the components of an ASM.

61

3.6 Sequential Circuits

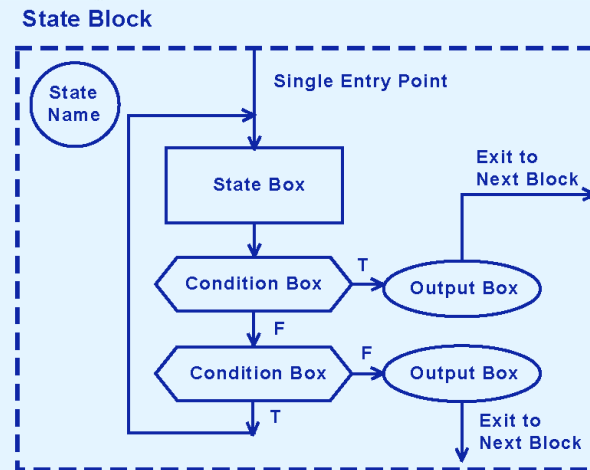

62

3.6 Sequential Circuits

- This is an ASM for a microwave oven.

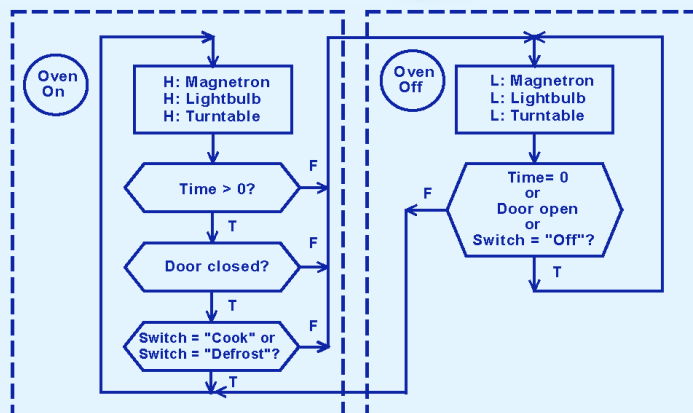

63

3.6 Sequential Circuits

- Sequential circuits are used anytime that we have a “stateful” application.
 - A stateful application is one where the next state of the machine depends on the current state of the machine and the input.
- A stateful application requires both combinational and sequential logic.
- The following slides provide several examples of circuits that fall into this category.

64

3.6 Sequential Circuits

- This illustration shows a 4-bit register consisting of D flip-flops. You will usually see its block diagram (below) instead.



A larger memory configuration is shown on the next slide.

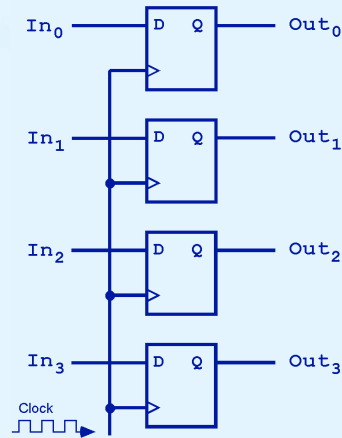

65

3.6 Sequential Circuits

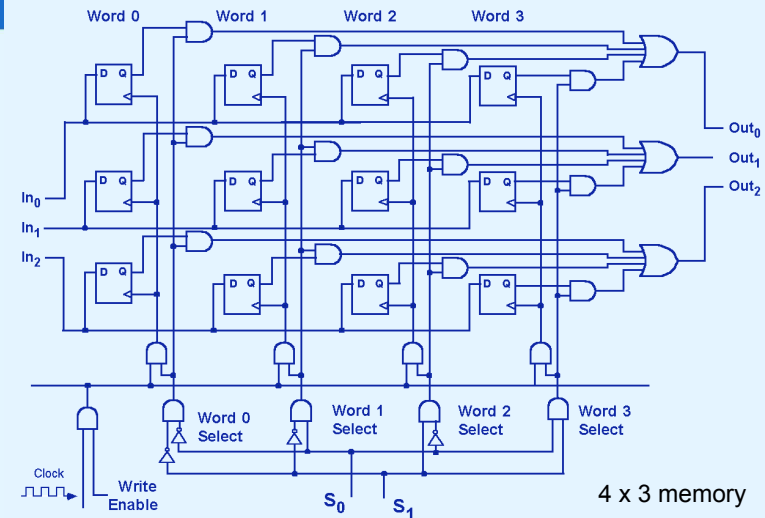

66

3.6 Sequential Circuits

- A binary counter is another example of a sequential circuit.
- The low-order bit is complemented at each clock pulse.
- Whenever it changes from 0 to 1, the next bit is complemented, and so on through the other flip-flops.

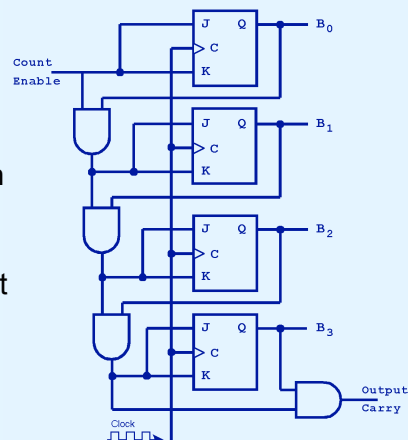

67

3.7 Designing Circuits

- We have seen digital circuits from two points of view: digital analysis and digital synthesis.
 - Digital analysis* explores the relationship between a circuit's inputs and its outputs.
 - Digital synthesis* creates logic diagrams using the values specified in a truth table.
- Digital systems designers must also be mindful of the physical behaviors of circuits to include minute propagation delays that occur between the time when a circuit's inputs are energized and when the output is accurate and stable.

68

3.7 Designing Circuits

- Digital designers rely on specialized software to create efficient circuits.
 - Thus, software is an enabler for the construction of better hardware.
- Of course, software is in reality a collection of algorithms that could just as well be implemented in hardware.
 - Recall the Principle of Equivalence of Hardware and Software.

69

3.7 Designing Circuits

- When we need to implement a simple, specialized algorithm and its execution speed must be as fast as possible, a hardware solution is often preferred.
- This is the idea behind *embedded systems*, which are small special-purpose computers that we find in many everyday things.
- Embedded systems require special programming that demands an understanding of the operation of digital circuits, the basics of which you have learned in this chapter.

70

Chapter 3 Conclusion

- Computers are implementations of Boolean logic.
- Boolean functions are completely described by truth tables.
- Logic gates are small circuits that implement Boolean operators.
- The basic gates are AND, OR, and NOT.
 - The XOR gate is very useful in parity checkers and adders.
- The “universal gates” are NOR, and NAND.

71

Chapter 3 Conclusion

- Computer circuits consist of combinational logic circuits and sequential logic circuits.
- Combinational circuits produce outputs (almost) immediately when their inputs change.
- Sequential circuits require clocks to control their changes of state.
- The basic sequential circuit unit is the flip-flop: The behaviors of the SR, JK, and D flip-flops are the most important to know.

72

Chapter 3 Conclusion



- The behavior of sequential circuits can be expressed using characteristic tables or through various finite state machines.
- Moore and Mealy machines are two finite state machines that model high-level circuit behavior.
- Algorithmic state machines are better than Moore and Mealy machines at expressing timing and complex signal interactions.
- Examples of sequential circuits include memory counters, and decoders.

73

End of Chapter 3

74